



US 20090267074A1

(19) **United States**

(12) **Patent Application Publication**
KWON et al.

(10) **Pub. No.: US 2009/0267074 A1**
(43) **Pub. Date: Oct. 29, 2009**

(54) **ORGANIC LIGHT EMITTING DISPLAY
DEVICE AND METHOD OF
MANUFACTURING THE SAME**

(30) **Foreign Application Priority Data**

Apr. 24, 2008 (KR) 2008-38255

Publication Classification

(75) Inventors: **Do-Hyun KWON**, Suwon-si (KR);
Il-Jeong Lee, Suwon-si (KR);
Choong-Youl Im, Suwon-si (KR);
Dae-Hyun No, Suwon-si (KR);
Jong-Mo Yeo, Suwon-si (KR);
Cheol-Ho Yu, Suwon-si (KR)

(51) **Int. Cl.**
H01L 51/50 (2006.01)
H01L 21/56 (2006.01)
(52) **U.S. Cl.** **257/72**; 438/29; 257/E51.018;
257/E21.158; 257/40; 313/504

(57) **ABSTRACT**

A organic light emitting display device includes a thin film transistor (TFT) having a gate electrode, a source electrode and a drain electrode which are insulated from the gate electrode, and a semiconductor layer which is insulated from the gate electrode and which contacts each of the source electrode and the drain electrode; and a pixel electrode electrically connected to one of the source electrode and the drain electrode. The gate electrode is made up of a first conductive layer and a second conductive layer on the first conductive layer, and the pixel electrode is formed of the same material as the first conductive layer of the gate electrode.

Correspondence Address:
STEIN MCEWEN, LLP
1400 EYE STREET, NW, SUITE 300
WASHINGTON, DC 20005 (US)

(73) Assignee: **Samsung Mobile Display Co., Ltd.**,
Suwon-si (KR)

(21) Appl. No.: **12/342,170**

(22) Filed: **Dec. 23, 2008**

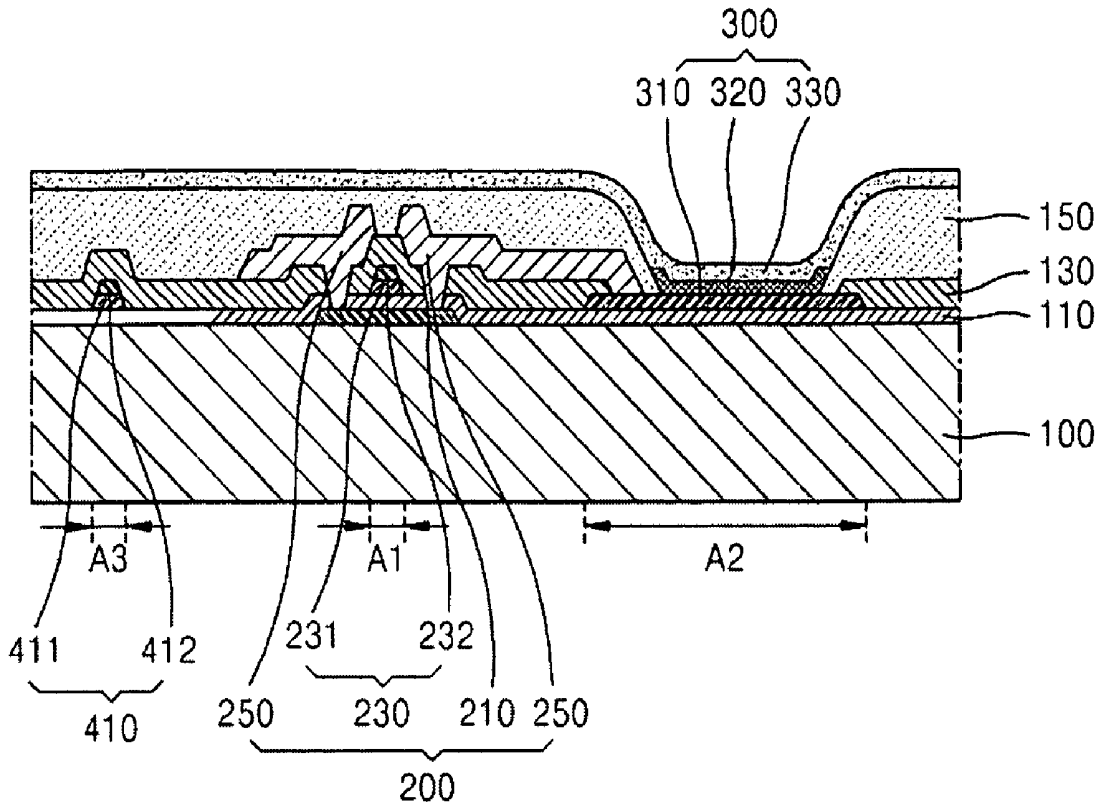

FIG. 1A (CONVENTIONAL ART)

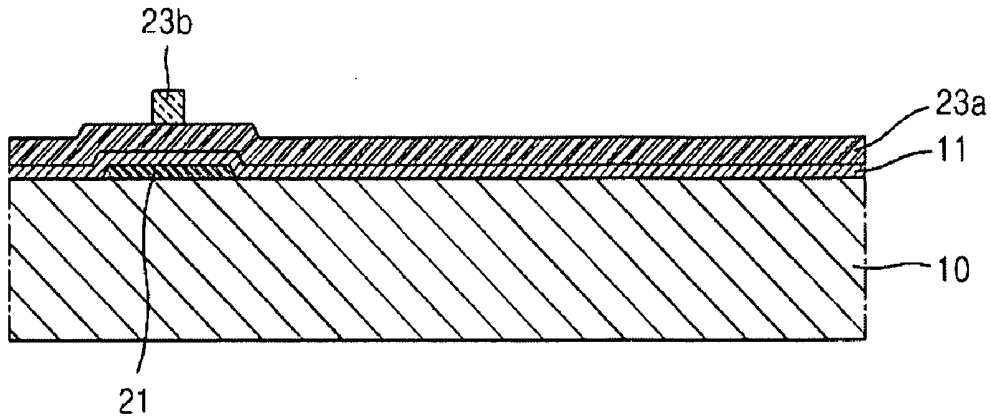

FIG. 1B (CONVENTIONAL ART)

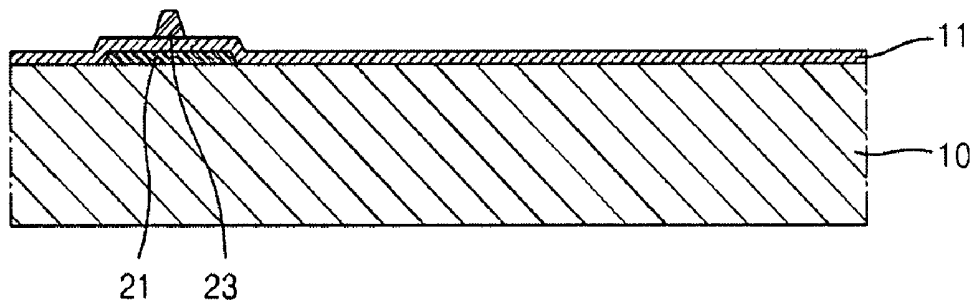

FIG. 1C (CONVENTIONAL ART)

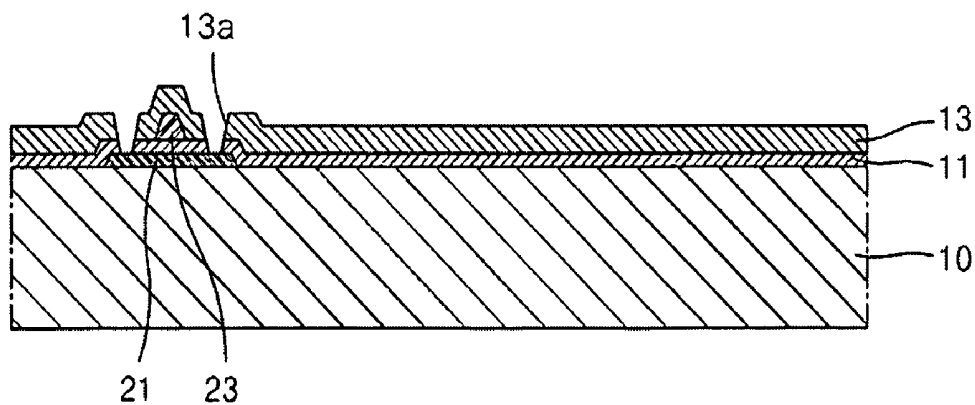

FIG. 1D (CONVENTIONAL ART)

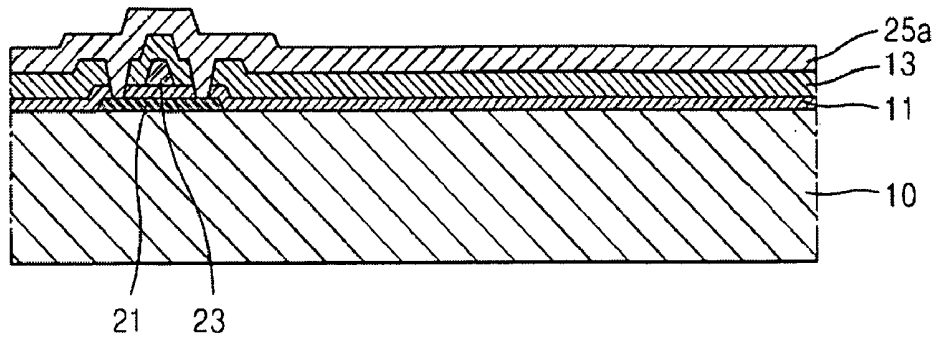

FIG. 1E (CONVENTIONAL ART)

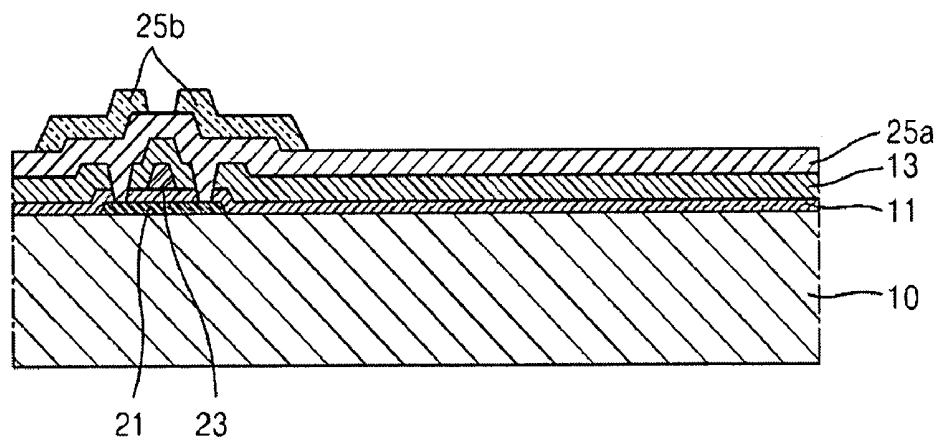

FIG. 1F (CONVENTIONAL ART)

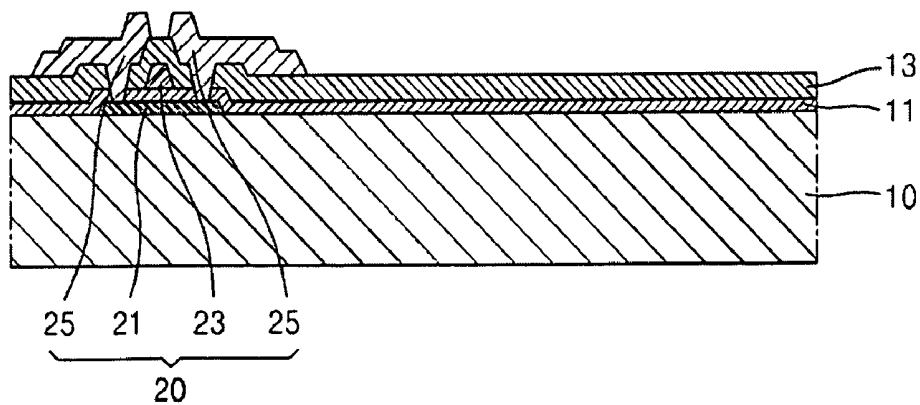

FIG. 1G (CONVENTIONAL ART)

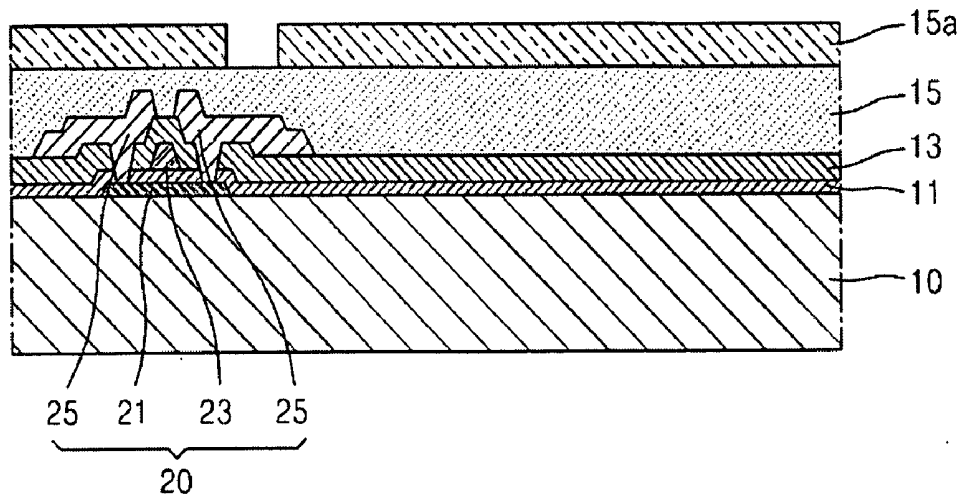

FIG. 1H (CONVENTIONAL ART)

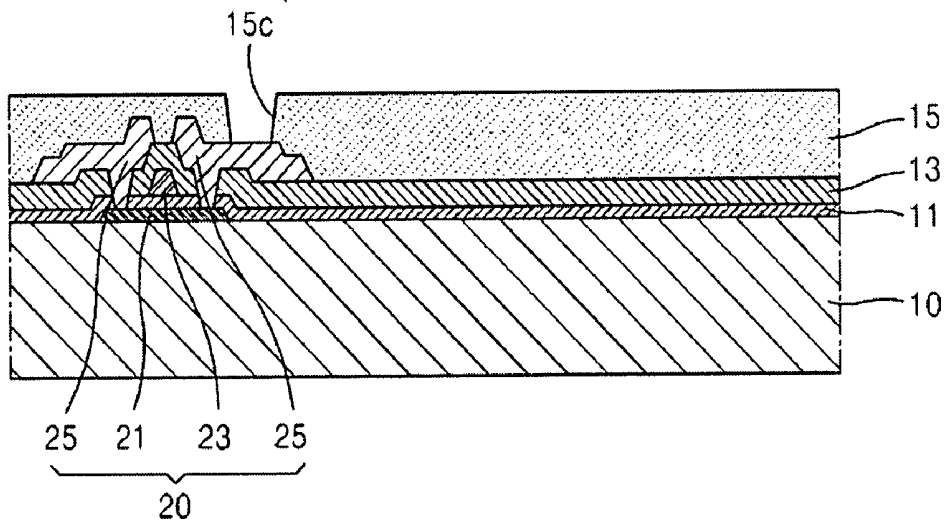

FIG. 1I (CONVENTIONAL ART)

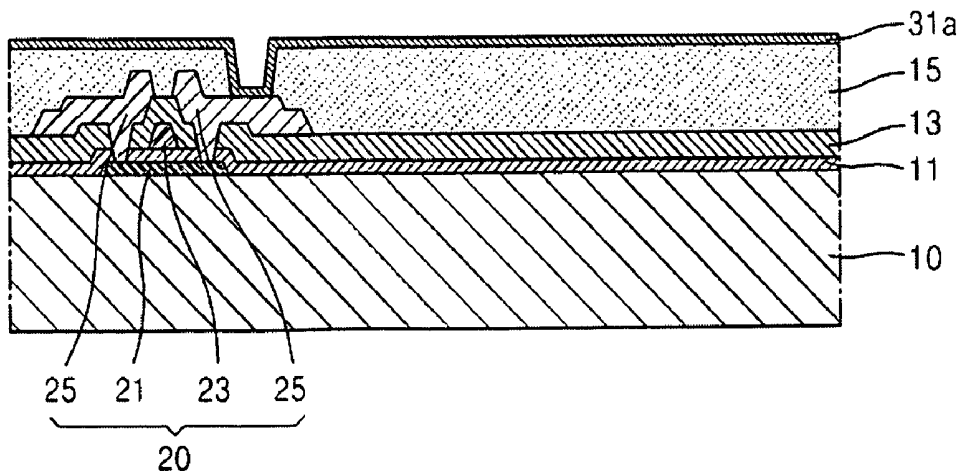

FIG. 1J (CONVENTIONAL ART)

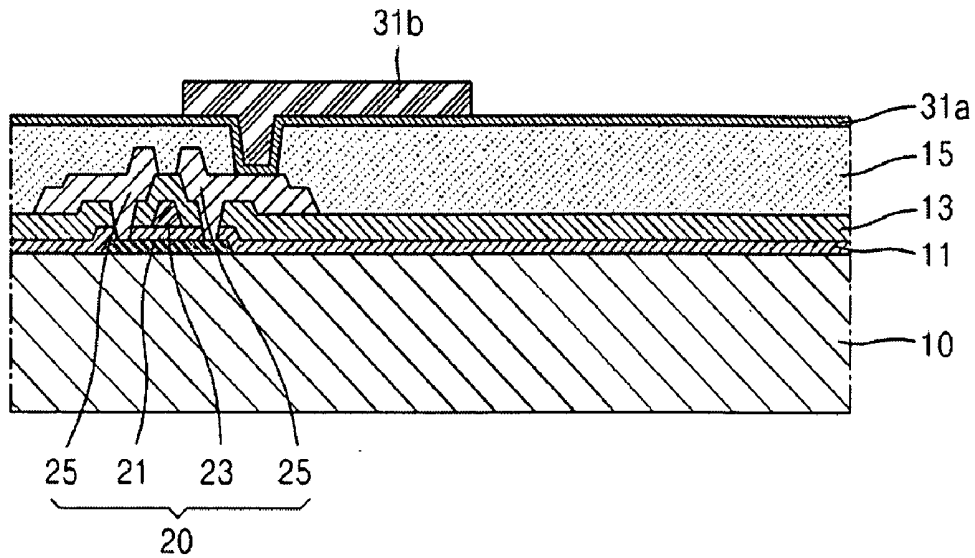

FIG. 1K (CONVENTIONAL ART)

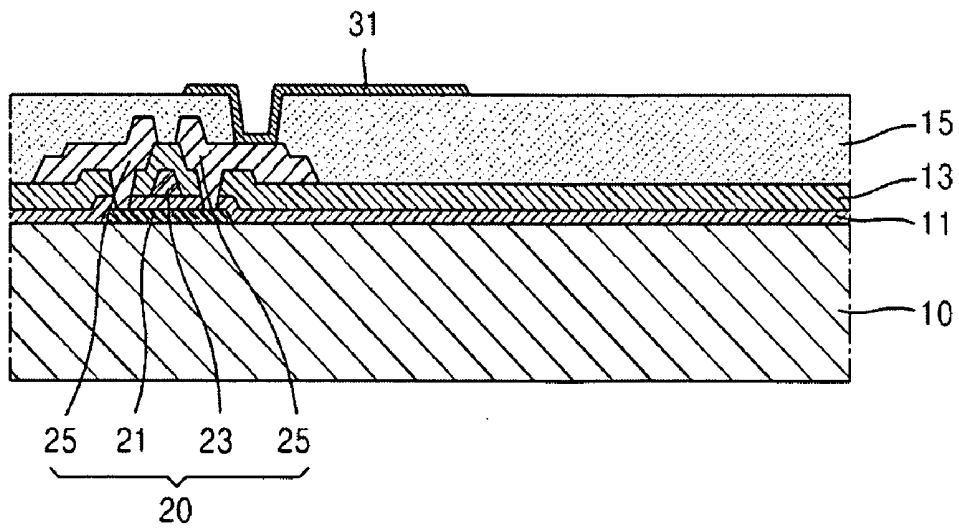

FIG. 1L (CONVENTIONAL ART)

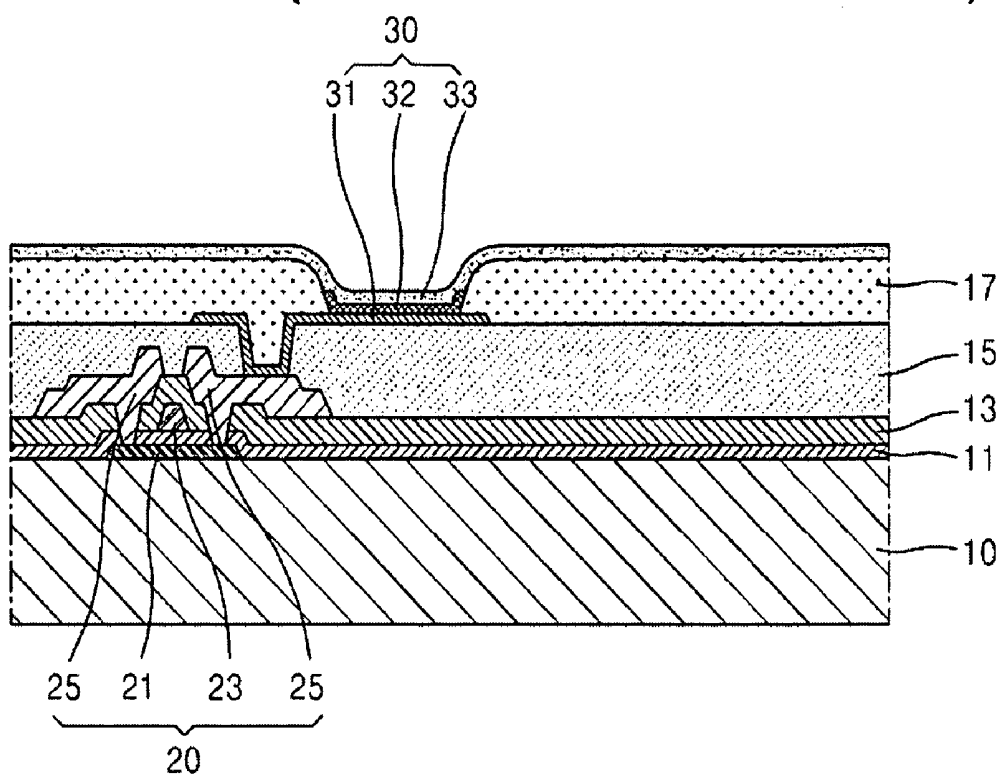

FIG. 2A

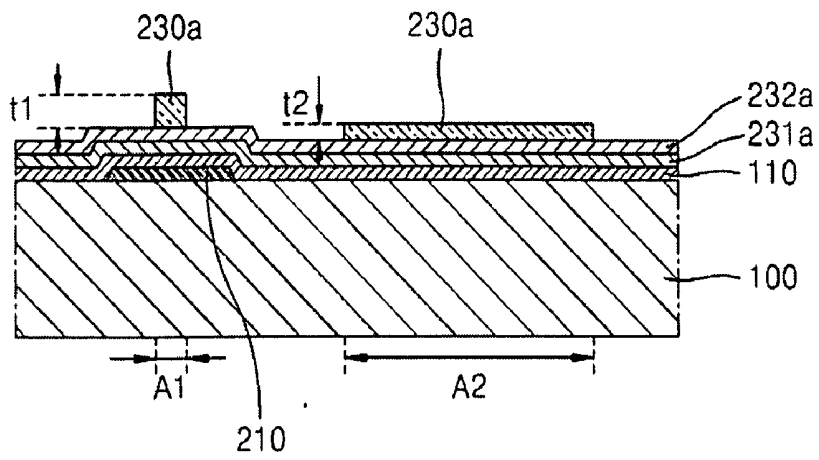

FIG. 2B

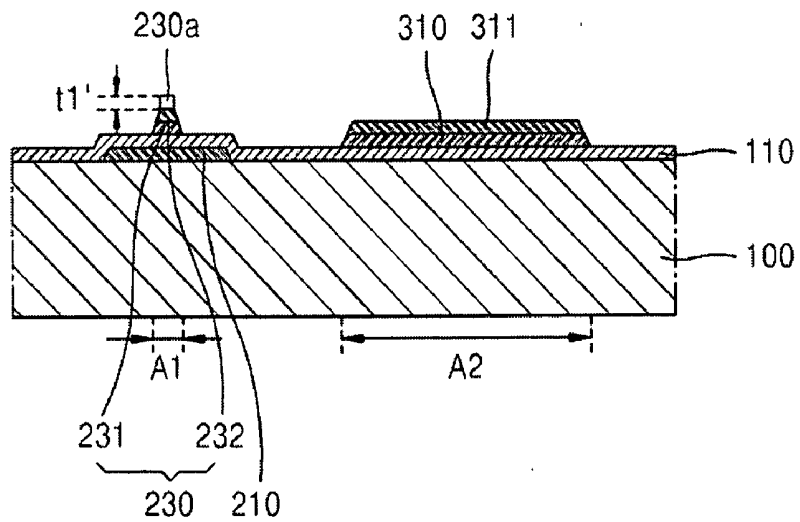

FIG. 2C

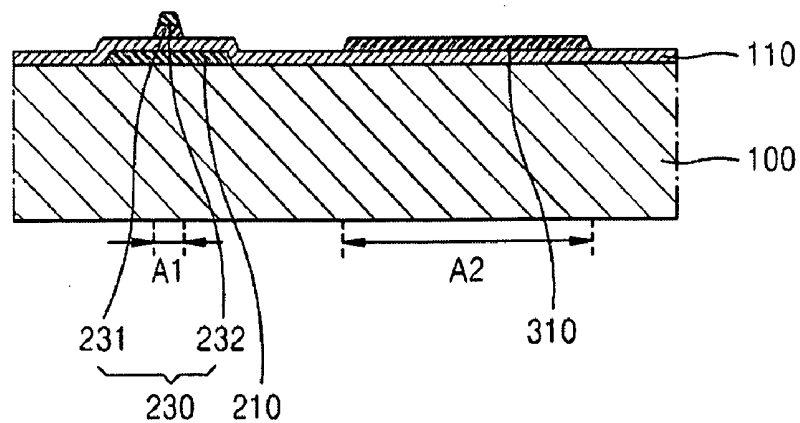

FIG. 2D

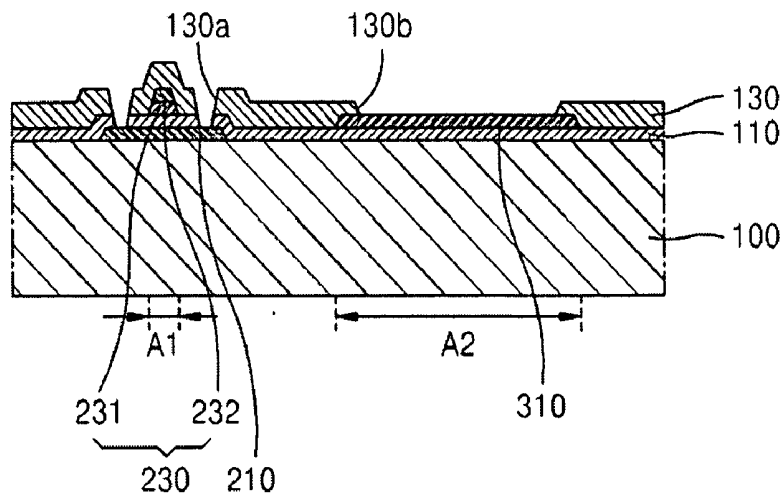

FIG. 2E

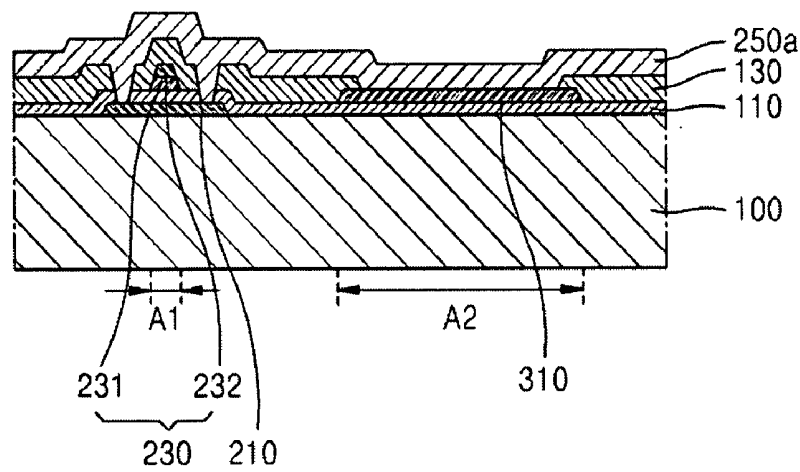

FIG. 2F

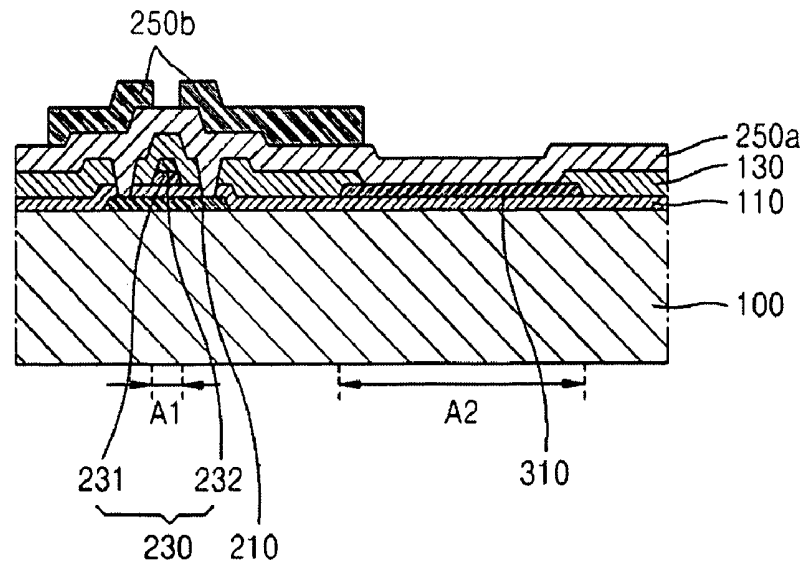

FIG. 2G

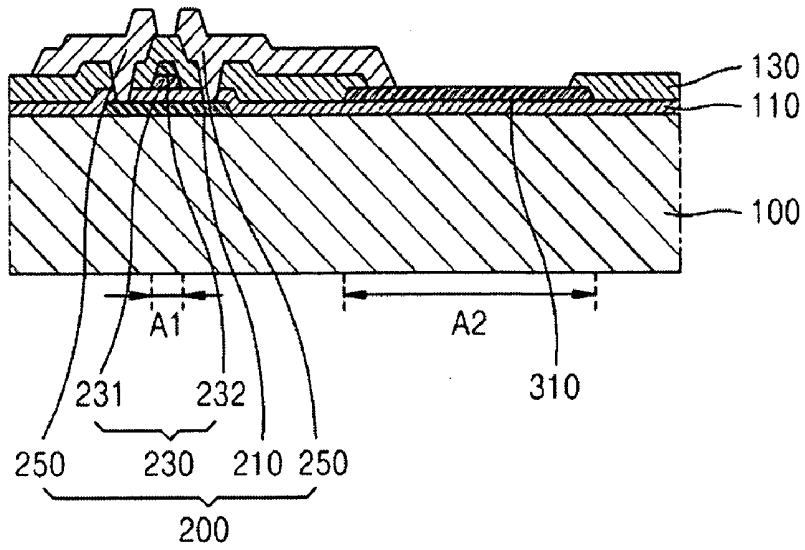

FIG. 2H

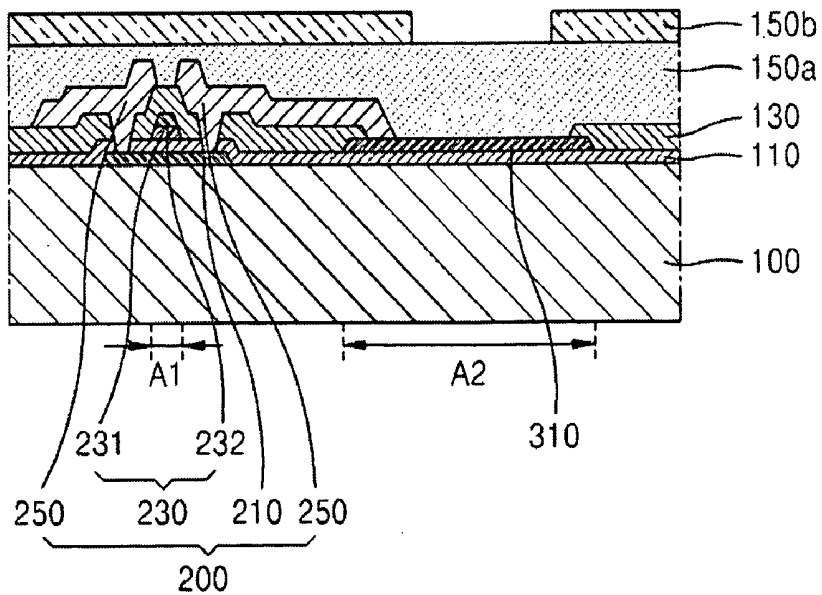

FIG. 2I

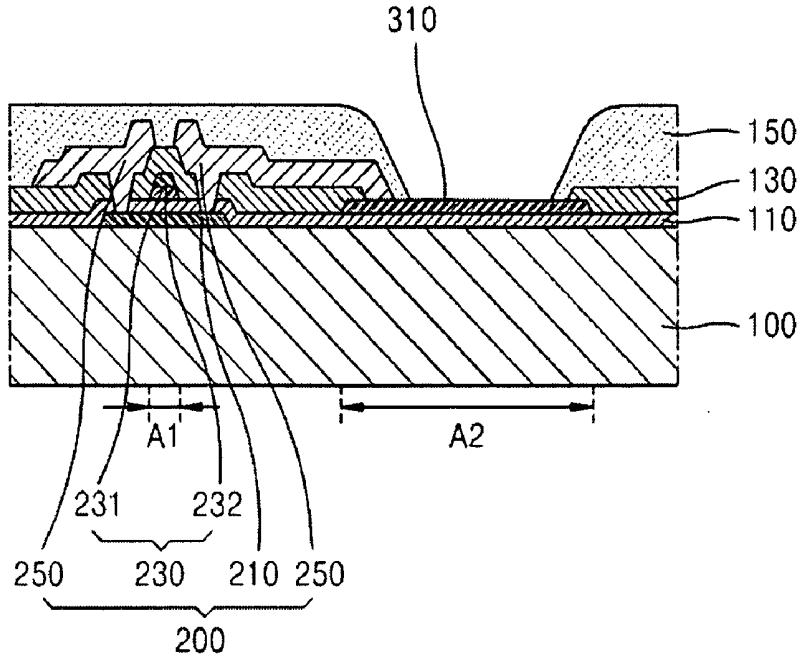

FIG. 2J

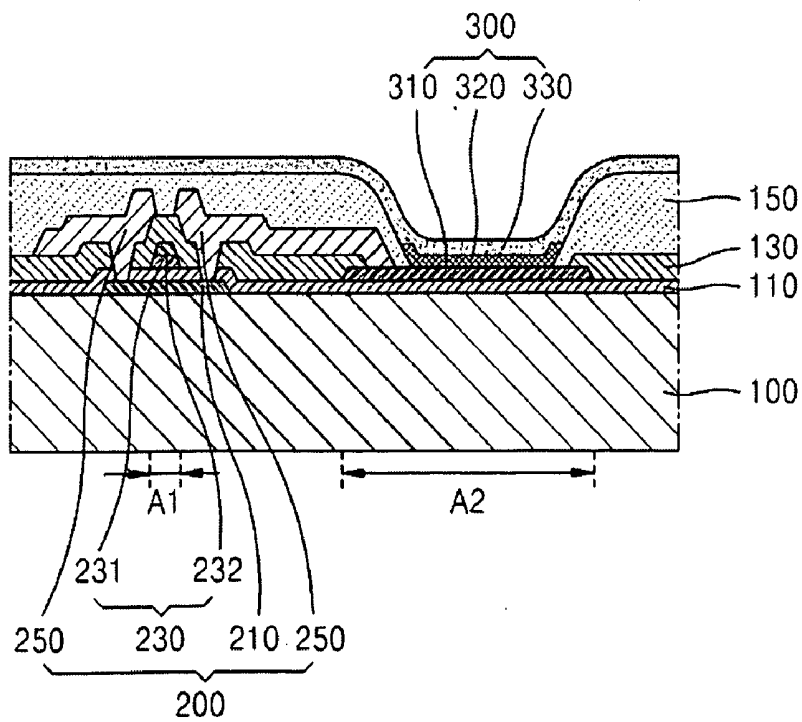

FIG. 3A

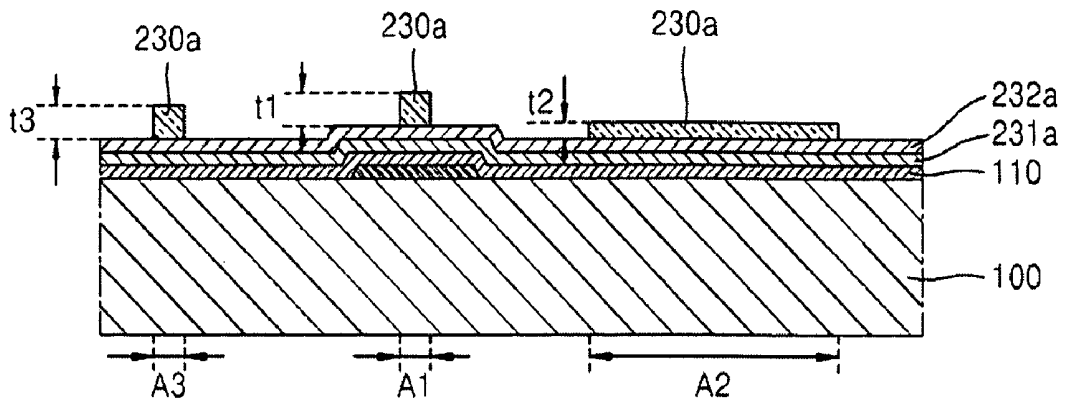

FIG. 3B

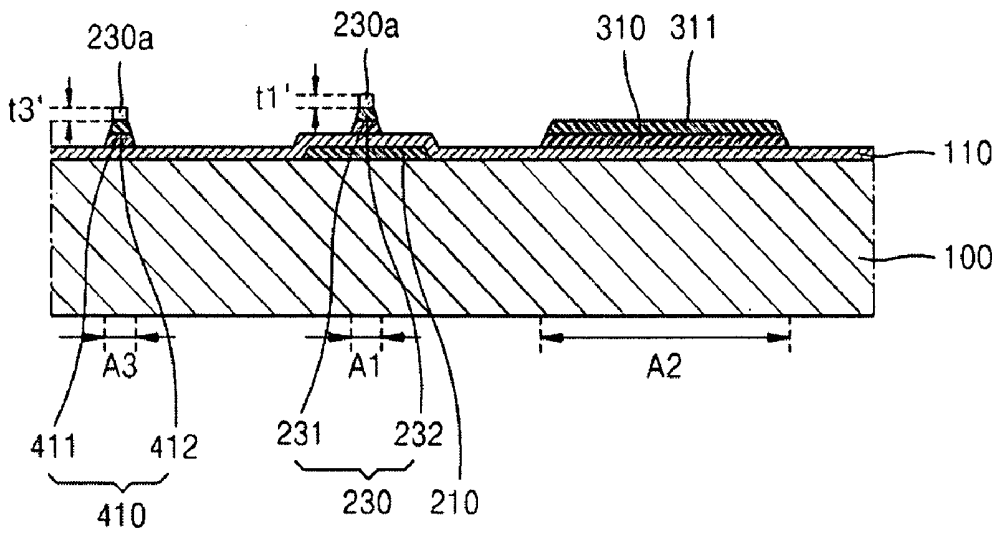

FIG. 3C

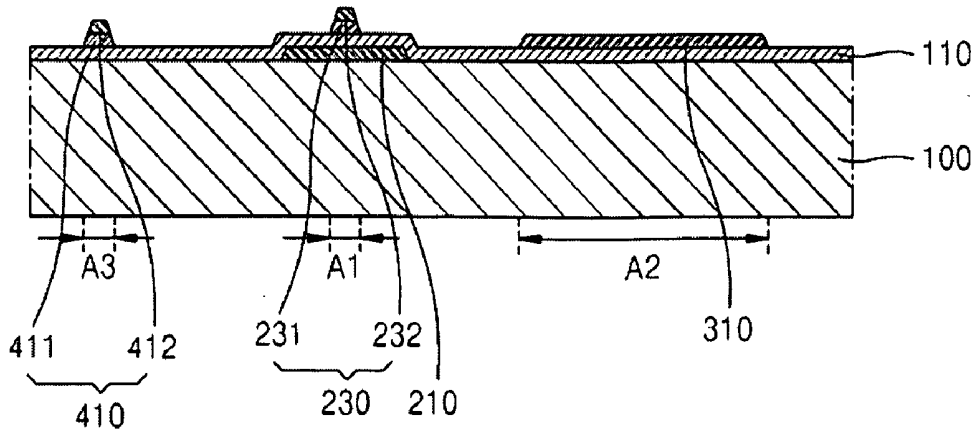
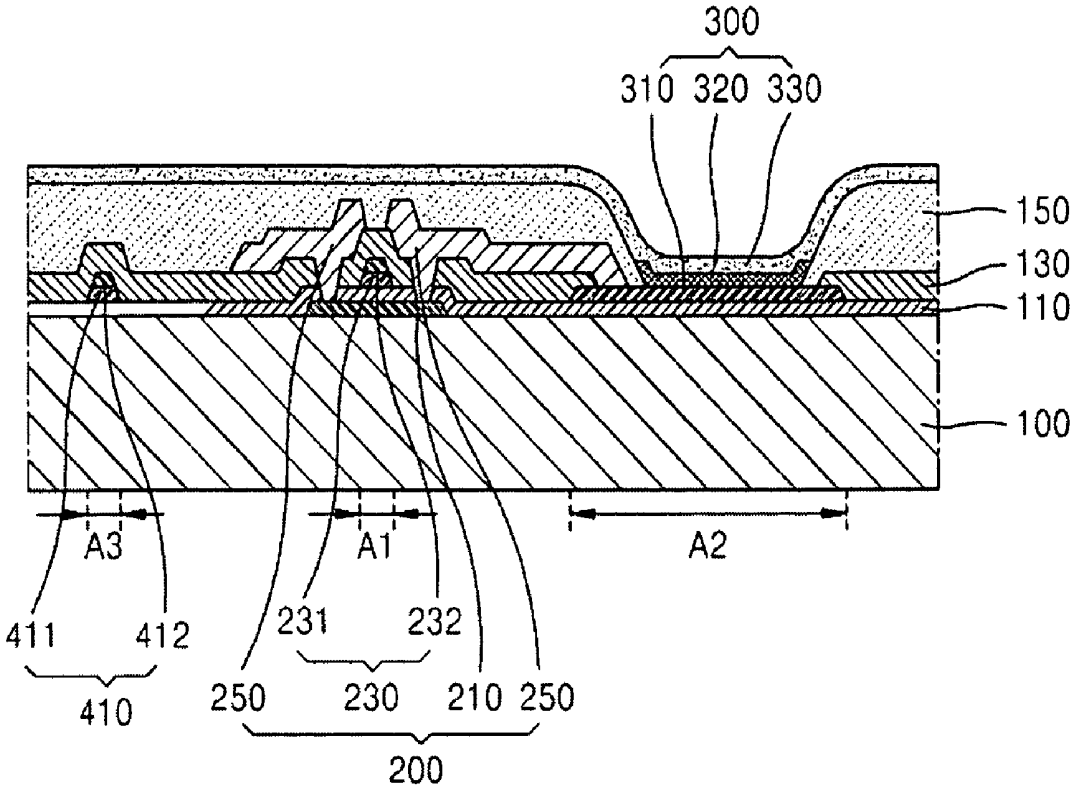

FIG. 3D



**ORGANIC LIGHT EMITTING DISPLAY
DEVICE AND METHOD OF
MANUFACTURING THE SAME**

CROSS-REFERENCE TO RELATED PATENT
APPLICATION

[0001] This application claims the benefit of Korean Patent Application No. 2008-38255, filed on Apr. 24, 2008 in the Korean Intellectual Property Office, the disclosure of which is incorporated herein in its entirety by reference.

BACKGROUND OF THE INVENTION

[0002] 1. Field of the Invention

[0003] Aspects of the present invention relate to an organic light emitting display device and a method of manufacturing the same, and more particularly, to an organic light emitting display device and a method of manufacturing the same which reduces the number of times that masks are used, reduces manufacturing costs, and simplifies manufacture thereof.

[0004] 2. Description of the Related Art

[0005] In general, an organic light emitting display device is a flat display device that includes organic light emitting diodes (OLEDs) as display elements, wherein each OLED has a pixel electrode, a counter electrode facing the pixel electrode, and an intermediate layer including an emission layer disposed between the pixel electrode and the counter electrode. Such an organic light emitting display device includes thin film transistors (TFTs) that control the function of each OLED.

[0006] FIGS. 1A through 1L are cross-sectional views for illustrating a conventional method of manufacturing an organic light emitting display device. According to the conventional method, as illustrated in FIG. 1A, a semiconductor layer 21 is patterned and formed on a substrate 10, a gate insulating layer 11 is formed to cover the semiconductor layer 21, a conductive layer 23a to be formed as a gate electrode is formed on the gate insulating layer 11, and a photoresist layer 23b for the gate electrode is formed on a portion of the conductive layer 23a. To produce the structure as illustrated in FIG. 1A, a first mask process is performed to pattern the semiconductor layer 21, and a second mask process is performed to form the photoresist layer 23b for the gate electrode.

[0007] Next, as illustrated in FIG. 1B, the gate electrode 23 is formed by patterning the conductive layer 23a for the gate electrode by using the photoresist layer 23b. Then, as illustrated in FIG. 1C, after an intermediate insulating layer 13 is formed to cover the gate electrode 23, a third mask process is performed to form via holes 13a, exposing a part of the semiconductor layer 21.

[0008] After the via holes 13a are formed, a conductive layer 25a for source/drain electrodes is formed as illustrated in FIG. 1D so that the conductive layer 25a for the source/drain electrodes contacts the semiconductor layer 21 through the via holes 13a. Next, as illustrated in FIG. 1E, a fourth mask process is performed to form a photoresist layer 25b on a portion of the conductive layer 25a for the source/drain electrodes. Next, by patterning the conductive layer 25a for the source/drain electrodes using the photoresist layer 25b, source/drain electrodes 25 insulated from the gate electrode 23 and respectively contacting the semiconductor layer 21 are formed to complete a TFT 20, as illustrated in FIG. 1F.

[0009] Then, as illustrated in FIG. 1G, a planarization layer 15 is formed to cover the source/drain electrodes 25, and a fifth mask process is performed to form a photoresist layer 15a for a contact hole on an entire surface of the planarization layer 15, except for where the contact hole is to be formed. Next, by etching the planarization layer 15 using the photoresist layer 15a for the contact hole, one of the source/drain electrodes 25 is exposed by the contact hole 15c formed in the planarization layer 15, as illustrated in FIG. 1H.

[0010] Next, as illustrated in FIG. 1I, a conductive layer 31a for a pixel electrode is formed to cover the planarization layer 15 and contact one of the source/drain electrodes 25 via the contact hole 15c. Then, a sixth mask process is performed to form a photoresist layer 31b for the pixel electrode on the conductive layer 31a so as to correspond to an area where a pixel electrode is to be formed. By patterning the conductive layer 31a using the photoresist layer 31b, a pixel electrode 31 that contacts one of the source/drain electrodes 25 is formed, as illustrated in FIG. 1K. Then, an insulating layer for a pixel defining layer is formed to cover the pixel electrode 31, and the insulating layer is patterned via a seventh mask process to form a pixel defining layer 17 in which at least a part of the pixel electrode 31 is exposed. Then, as illustrated in FIG. 1L, an intermediate layer 32 including an emission layer is formed on the pixel electrode 31 via an eighth mask process, and a counter electrode 33 is formed to cover an entire display area, thereby forming an active matrix (AM) organic light emitting display device having an OLED 30 as a pixel, the emission of which is controlled by the TFT 20.

[0011] However, according to the above described conventional method of manufacturing the organic light emitting display device, since a total of eight mask processes have to be performed to form the TFT 20 and the OLED 30, many masks are used and the process is very complicated. Thus, the manufacturing costs of the display device are high and the yield is low.

SUMMARY OF THE INVENTION

[0012] Aspects of the present invention provide an organic light emitting display device and a method of manufacturing the same which reduces the number of times that masks are used, reduces manufacturing costs, and simplifies manufacture thereof.

[0013] According to an embodiment of the present invention, there is provided an organic light emitting display device including: a thin film transistor (TFT) having a gate electrode, a source electrode and a drain electrode which are insulated from the gate electrode, and a semiconductor layer which is insulated from the gate electrode and which contacts each of the source electrode and the drain electrode; and a pixel electrode electrically connected to one of the source electrode and the drain electrode, wherein the gate electrode comprises a first conductive layer and a second conductive layer on the first conductive layer, and the pixel electrode is formed of a same material as the first conductive layer of the gate electrode on a same layer as the first conductive layer of the gate electrode.

[0014] According to an aspect of the present invention, the first conductive layer may be formed of a transparent conductive material.

[0015] According to an aspect of the present invention, the organic light emitting display device may further include a wiring electrically connected to the gate electrode, wherein the wiring may comprise a first layer of conductive material

on the same layer as the first conductive layer of the gate electrode and a second layer of conductive material on a same layer as the second conductive layer of the gate electrode.

[0016] According to an aspect of the present invention, the wiring may be formed of the same material as the gate electrode.

[0017] According to another embodiment of the present invention, there is provided a method of manufacturing an organic light emitting display device, the method including forming a first conductive layer and a second conductive layer on the first conductive layer, the first conductive layer being formed on a substrate; forming a patterned photoresist layer on a first area of the second conductive layer corresponding to where a gate electrode is to be formed and on a second area of the second conductive layer corresponding to where a pixel electrode is to be formed, wherein the patterned photoresist layer has a greater thickness at the first area than at the second area; patterning the first conductive layer and the second conductive layer by removing portions of the first conductive layer and the second conductive layer not covered by the patterned photoresist layer and removing the patterned photoresist layer on the second area; and removing the second conductive layer of the second area to form the pixel electrode and removing the patterned photoresist layer remaining on the first area to form the gate electrode.

[0018] According to an aspect of the present invention, the first conductive layer may be formed of a transparent conductive material.

[0019] According to an aspect of the present invention, the method may further include forming the patterned photoresist layer on a third area corresponding to where a wiring electrically connected to the gate electrode is to be formed, concurrently with the forming of the patterned photoresist layer on the first area and the second area, and wherein the thickness of the photoresist layer on the third area is greater than the thickness of the patterned photoresist layer on the second area.

[0020] According to an aspect of the present invention, the thickness of the patterned photoresist layer on the third area may be equal to the thickness of the patterned photoresist layer on the first area.

[0021] According to an aspect of the present invention, the forming of the patterned photoresist layer on the first area and the second area may be carried out using a halftone mask.

[0022] According to another embodiment of the present invention, there is provided a method of manufacturing an organic light emitting display device, the method comprising forming a semiconductor layer on a substrate; forming a gate insulating layer on the substrate and on the semiconductor layer; forming a first conductive layer on the gate insulating layer and forming a second conductive layer on the first conductive layer; forming a patterned photoresist layer on a first area of the second conductive layer corresponding to where a gate electrode is to be formed and on a second area of the second conductive layer corresponding to where a pixel electrode is to be formed, wherein the first area has a greater thickness than a second area; patterning the first conductive layer and the second conductive layer by removing portions of the first conductive layer and the second conductive layer not covered by the photoresist layer, removing the photoresist layer on the second area and partially removing the patterned photoresist layer on the first area; removing the second conductive layer of the second area to form the pixel electrode and the photoresist layer remaining on the first area to form

the gate electrode; and forming source and drain electrodes electrically contacting the semiconductor layer, and wherein one of the source electrode and the drain electrode electrically contacts the pixel electrode.

[0023] According to another embodiment of the present invention, there is provided a method of manufacturing an organic light emitting display device, the method comprising concurrently forming a gate electrode and a pixel electrode using a same mask process.

[0024] Additional aspects and/or advantages of the invention will be set forth in part in the description which follows and, in part, will be obvious from the description, or may be learned by practice of the invention

BRIEF DESCRIPTION OF THE DRAWINGS

[0025] These and/or other aspects and advantages of the invention will become apparent and more readily appreciated from the following description of the embodiments, taken in conjunction with the accompanying drawings of which:

[0026] FIGS. 1A through 1L are cross-sectional views that illustrate a conventional method of manufacturing an organic light emitting display device;

[0027] FIGS. 2A through 2J are cross-sectional views that illustrate a method of manufacturing an organic light emitting display device according to an embodiment of the present invention, with FIG. 2J illustrating the organic light emitting display device manufactured thereby; and

[0028] FIGS. 3A through 3D are cross-sectional views that illustrate a method of manufacturing an organic light emitting display device according to another embodiment of the present invention, with FIG. 3D illustrating the organic light emitting display device manufactured thereby.

DETAILED DESCRIPTION OF THE EMBODIMENTS

[0029] Reference will now be made in detail to the present embodiments of the present invention, examples of which are illustrated in the accompanying drawings, wherein like reference numerals refer to the like elements throughout. The embodiments are described below in order to explain the present invention by referring to the figures.

[0030] Herein, it is to be understood that where it is stated herein that one layer is "formed on" or "disposed on" a second layer, the first layer may be formed or disposed directly on the second layer or there may be intervening layers between the first layer and the second layer. Further, when used herein to describe a device, the term "formed on" is used with the same meaning as "located on" or "disposed on" and is not meant to be limiting regarding any particular fabrication process.

[0031] FIGS. 2A through 2J are cross-sectional views that illustrate a method of manufacturing an organic light emitting display device according to an embodiment of the present invention. First, the multilayer body illustrated in FIG. 2A is formed. In particular, a patterned semiconductor layer **210** is formed on a substrate **100** via a first mask process. The substrate **100** can be formed of any suitable material such as, for example, a glass material, a plastic material such as an acrylic, or a metal plate. If desired, a buffer layer (not shown) may be formed on the substrate **100** before the semiconductor layer **210** is formed.

[0032] After the semiconductor layer **210** is formed, a gate insulating layer **110** is formed to cover the substrate **100** and the semiconductor layer **210**. The gate insulating layer may

be formed of an insulating material such as silicone oxide or silicone nitride. Then, a first conductive layer 231a is formed on the gate insulating layer 110, and a second conductive layer 232a are formed on the first conductive layer 231a. The first conductive layer 231a may be formed of a transparent conductive material such as ITO, IZO, In₂O₃ or the like, and the second conductive layer 232a may be formed of a conductive material such as Mo, W, Al, Cu, Ag, or an alloy formed of the aforementioned various conductive materials. In particular, for reasons that will be discussed later, the first conductive layer 231a may be formed of a conductive material (such as indium tin oxide (ITO), indium zinc oxide (IZO), In₂O₃ or the like) that is relatively difficult to remove by etching, and the second conductive layer 232a may be formed of a conductive material (such as Mo, W, Al, Cu, Ag, or an alloy thereof) that is relatively easy to remove by etching. The first conductive layer 231a and the second conductive layer 232a may be formed sequentially. That is, the first conductive layer 231a may be formed on the gate insulating layer 110, and then the second conductive layer 232a may be formed of the first conductive layer 231a. Alternatively, the first conductive layer 231a and the second conductive layer 232a may be applied concurrently to the gate insulating layer 110, for example, by the use of a laser induced thermal induction (LITI) process.

[0033] After the first conductive layer 231a and the second conductive layer 232a are formed, a photoresist layer 230a is formed on areas of the second conductive layer 232a via a second mask process. In particular, the photoresist layer 230a is formed at a first area A1 corresponding to where a gate electrode 230 (see FIG. 2C) is to be formed and at a second area A2 corresponding to where a pixel electrode 210 (see FIG. 2C) is to be formed. The photoresist layer 230a is formed in such a manner that the thickness t1 of first area A1 is greater than the thickness t2 of second area A2. The formation of the photoresist layer 230a having different thicknesses may be accomplished using a single mask process using, for example, a halftone mask.

[0034] After the photoresist layer 230a is formed, the first conductive layer 231a and the second conductive layer 232a are patterned, that is, the parts of the first conductive layer 231a and the second conductive layer 232a that are not covered by the photoresist layer 230a are removed by dry etching. The photoresist layer 230a on the second area A2 is also removed. In particular, in the dry etching process, the photoresist layer 230a on the first area A1 and the photoresist layer 230a on the second area A2 are etched. Since the thickness t1 of the photoresist layer 230a on the first area A1 is greater than the thickness t2 of the photoresist layer 230a on the second area A2, the etching does not completely remove the photoresist layer 230a on the first area A1, although the photoresist layer 230a on the second area A2 is removed. The photoresist layer 230a on the first area A1 maintains a thickness t1', as illustrated in FIG. 2B.

[0035] When the first conductive layer 231a and the second conductive layer 232a are patterned, at area A1, a gate electrode 230 is formed of a remaining portion of the first conductive layer 231 and a remaining portion of the second conductive layer 232. At area A2, a pixel electrode 310 and a second conductive material layer 311 are formed of same material as the first conductive layer 231 and the second conductive layer 232 of the gate electrode 230.

[0036] Then, by removing the second conductive material layer 311 from the second area A2 and the photoresist layer

230a from the first area A1, a multilayer body is obtained as illustrated in FIG. 2C, wherein, in the multilayer body, the gate electrode 230 including the first conductive layer 231 and the second conductive layer 232 on the first conductive layer 231 is disposed on the first area A1, and the pixel electrode 310, which is formed by using the same material as the first conductive layer 231 of the gate electrode 230 on a same layer as the first conductive layer 231 of the gate electrode 230, is disposed on the second area A2.

[0037] The second conductive material layer 311 on the second area A2 and the photoresist layer 230a remaining on the first area A1 may be removed by dry etching to obtain the structure shown in FIG. 2C. As described above with reference to FIG. 2A, when the first conductive layer 231a is formed of a transparent conductive material that is relatively difficult to remove by etching, such as ITO, IZO, In₂O₃ and the like, and the second conductive layer 232a is formed of a conductive material that is relatively easy to remove by etching, such as Mo, W, Al, Cu, Ag, or an alloy thereof, then, when dry etching is performed to the multilayer body illustrated in FIG. 2B, the second conductive material layer 311 in the second area A2 is easily etched but the pixel electrode 310 is not etched nor over-etched but remains, thereby obtaining the multilayer body illustrated in FIG. 2C.

[0038] As can be seen from the above description, both the gate electrode 230 and the pixel electrode 310 may be formed after performing only two mask processes. By contrast, in the conventional method of manufacturing the organic light emitting display device described with reference to FIGS. 1A through 1L, only two mask processes are required to form the gate electrode 23, but separate mask processes are further required to form the pixel electrode 31. Thus, the conventional method requires more mask processes than are used in the method of manufacturing the organic light emitting display device according to the current embodiment of the present invention. Hence, according to the method of manufacturing the organic light emitting display device according to the current embodiment of the present invention, a manufacturing process may be simplified, manufacturing costs may be reduced, and yield may be increased.

[0039] Next, after the gate electrode 230 and the pixel electrode 310 are formed as illustrated in FIG. 2C, an intermediate insulating layer 130 is formed to cover the gate electrode 230 and the pixel electrode 310. Then, as illustrated in FIG. 2D, via holes 130a exposing a part of the semiconductor layer 210, and an opening 130b exposing at least a part of the pixel electrode 310 are formed through a third mask process. The third mask process may also use a photoresist. Moreover, since the pixel electrode 310 is formed of a material that is difficult to etch, the pixel electrode 310 is not over-etched but is only exposed, regardless of whether dry etching or wet etching is used to form the opening 130b.

[0040] After the via holes 130a and the opening 130b are formed, a conductive layer 250a for source/drain electrodes is formed as illustrated in FIG. 2E so that the conductive layer 250a contacts the semiconductor layer 210 through the via holes 130a. Also, the conductive layer 250a contacts the pixel electrode 310 through the opening 130b. The conductive layer 250a may be formed of a conductive materials such as Ag, Mg, Al, Pt, Pd, Au, Ni, Nd, Ir, Cr, or a compound formed thereof.

[0041] Next, a fourth mask process is performed to form a photoresist layer 250b for the source/drain electrodes on a portion of the conductive layer 250a where the source/drain

electrodes are to be formed, as illustrated in FIG. 2F. Then, by patterning the conductive layer 250a by using the photoresist layer 250b, source/drain electrodes 250 insulated from the gate electrode 230 and respectively contacting the semiconductor layer 210 are formed to complete a thin film transistor (TFT) 200, as illustrated in FIG. 2G.

[0042] As described above, since the pixel electrode 310 is formed of a transparent conductive material that is relatively difficult to etch, such as ITO, IZO, In_2O_3 and the like, the pixel electrode 310 is not etched nor over-etched when the source/drain electrodes 250 are formed, but remains. Thereby, the multilayer body illustrated in FIG. 2G is obtained.

[0043] As illustrated in FIG. 2F, the photoresist layer 250b for the source/drain electrodes is structured such that after etching the conductive layer 250a to form the source/drain electrodes 250, one of the source/drain electrodes 250 contacts the pixel electrode 310, as illustrated in FIG. 2G.

[0044] Then, as illustrated in FIG. 2H, an insulating layer 150a for a pixel defining layer is formed to cover the source/drain electrodes 250 and the pixel electrode 310, and a fifth mask process is performed so that a photoresist layer 150b for the pixel defining layer is formed on the insulating layer 150a, except for where an opening exposing at least a part of the pixel electrode 310 is to be formed. The insulating layer 150a may be formed of an insulating material such as silicone oxide or silicone nitride. Then, the insulating layer 150a is etched using the photoresist layer 150b so that a pixel defining layer 150 exposing at least a part of the pixel electrode 310 is formed as illustrated in FIG. 2I. Then, an intermediate layer 320 including an emission layer is formed on the pixel electrode 310 through a sixth mask process, and a counter electrode 330 is formed to cover the entire display area. As illustrated in FIG. 2J, an active matrix (AM) organic light emitting display device having an organic light emitting diode (OLED) 300 as a pixel, whose emission is controlled by the TFT 200 is thereby manufactured.

[0045] The intermediate layer 320 of the OLED 300 may be formed of a small molecular weight material or a polymer material. When a small molecular weight material is used, the intermediate layer 320 may be formed by stacking an emission layer (EML) and one or more of a hole injection layer (HIL), a hole transport layer (HTL), an electron transport layer (ETL), and an electron injection layer (EIL) in a single-layer or multilayer structure, and various organic materials such as copper phthalocyanine (CuPc), N,N'-di(naphthalene-1-yl)-N,N'-diphenyl-benzidine (NPB), tris-8-hydroxyquinoline aluminum (Alq3), and the like may be used. These layers may be formed by using a vacuum deposition method. When a polymer materials is used, in general, the intermediate layer 320 may include an HTL and an EML. For example, poly(3,4-ethylenedioxythiophene) (PEDOT) may be used as the HTL, and a poly-phenylenevinylene (PPV)-based polymer material or a polyfluorene-based polymer materials may be used as the EML. The HTL and the EML may be formed by using a screen printing method or an ink-jet printing method. However, the structure of the intermediate layer 320 is not limited thereto but may vary.

[0046] The counter electrode 330 may be formed as a transparent electrode or as a reflective electrode. When the counter electrode 330 is a transparent electrode, the counter electrode 330 may include a layer formed of a metal having a low work function such as Li, Ca, LiF/Ca, LiF/Al, Al, Ag, Mg or a compound thereof, and a transparent conductive layer such as

ITO, IZO, ZnO or In_2O_3 . When the counter electrode 330 is a reflective electrode, the counter electrode 330 may be a layer formed of Li, Ca, LiF/Ca, LiF/Al, Al, Ag, Mg or a compound thereof. A structure and materials forming the counter electrode 330 are not limited thereto but may vary.

[0047] According to the conventional method of manufacturing the organic light emitting display device described with reference to FIGS. 1A through 1L, a total of eight mask processes are required. However, by using the method of manufacturing the organic light emitting display device according to the current embodiment of the present invention, an AM organic light emitting display device can be manufactured using only six mask processes. Thus, according to the method of manufacturing the organic light emitting display device according to the current embodiment of the present invention, a manufacturing process may be simplified, manufacturing costs may be reduced, and yield may be increased.

[0048] FIG. 2J illustrates an organic light emitting display device that is manufactured according to the method described above. The organic light emitting display device includes a TFT 200 and a pixel electrode 310 which is electrically connected to one of source/drain electrodes 250 of the TFT 200. A gate electrode 230 includes a first conductive layer 231 and a second conductive layer 232 disposed on the first conductive layer 231. The pixel electrode 310 is formed of the same material as the first conductive layer 231 of the gate electrode 230 on a same layer as the first conductive layer 231 of the gate electrode 230. Such a first conductive layer 231 may be formed of a transparent conductive material such as ITO, IZO or In_2O_3 . The organic light emitting display device according to the present embodiment has a simple structure and as described above, can be formed with fewer mask processes, thereby enabling an increase in the production yield and a reduction in manufacturing costs, compared to the conventional organic light emitting display device that is illustrated in FIG. 1L.

[0049] Furthermore, in the conventional organic light emitting display device of FIG. 1L, which was manufactured by using the conventional method, the pixel electrode 31 is disposed on a top surface of the TFT 20 such that the gate insulating layer 11, the intermediate insulating layer 13, and the planarization layer 15 are interposed between the substrate 10 and the pixel electrode 31. However, in the organic light emitting display device of FIG. 2J according to aspects of the present invention (manufactured by using the method of manufacturing the organic light emitting display device described above), the pixel electrode 310 is disposed on the same layer as the first conductive layer 231 of the gate electrode 230 such that only the gate insulating layer 110 is interposed between the pixel electrode 310 and the substrate 100. Thus, as can be seen in reference to FIG. 2J, in a bottom emission type organic light emitting display device, the number of layers through which a light emitted from the intermediate layer 320 passes before being emitted to the outside through the pixel electrode 310 and the substrate 100 is highly reduced, compared to the number of layers through which a light in the conventional organic light emitting display device passes before being emitted to the outside. Therefore, optical efficiency may be greatly enhanced.

[0050] Also, the number of layers included in the organic light emitting display device of FIG. 2J according to aspects of the present invention is reduced, compared to the number of layers included in the conventional organic light emitting display device of FIG. 1L. Thus, it may be possible to sim-

ply a structure of the organic light emitting display device so as to increase a yield and to reduce manufacturing costs.

[0051] FIGS. 3A through 3D are cross-sectional views to illustrate a method of manufacturing an organic light emitting display device according to another embodiment of the present invention.

[0052] First, a multilayer body as illustrated in FIG. 3A is formed. In particular, a semiconductor layer 210 patterned on a substrate 100 is formed through a first mask process. If desired, a buffer layer (not shown) may be formed on the substrate 100 before the semiconductor layer 210 is formed.

[0053] After the semiconductor layer 210 is formed, a gate insulating layer 110 is formed using an insulating material. Then, a first conductive layer 231a and a second conductive layer 232a on the first conductive layer 231a are formed on the gate insulating layer 110. The first conductive layer 231a may be formed of a transparent conductive material such as ITO, IZO, In_2O_3 , or the like, and the second conductive layer 232a may be formed of a conductive material such as Mo, W, Al, Cu, Ag, or an alloy formed thereof.

[0054] After the first conductive layer 231a and the second conductive layer 232a are formed, a photoresist layer 230a is formed on areas of the second conductive layer 232a through a second mask process. In particular, the photoresist layer 230a is formed at a first area A1 corresponding to where a gate electrode 230 (see FIG. 3C) is to be formed, at a second area A2 corresponding to where a pixel electrode 210 (see FIG. 3C) is to be formed, and at a third area A3, where a wiring electrically connected to the gate electrode 230 is to be formed. The photoresist layer 230a is formed in such a manner that a thickness t1 of a first area A1 where the gate electrode is to be formed is greater than a thickness t2 of a second area A2 where a pixel electrode is to be formed. A thickness t3 of the photoresist layer 230a on the third area A3 is also greater than the thickness t2 of the photoresist layer 230a on the second area A2. For example, the thickness t3 of the photoresist layer 230a on the third area A3 may be equal to the thickness t1 of the photoresist layer 230a on the first area A1. The formation of the photoresist layer 230a having different thicknesses may be accomplished using a single mask process using, for example, a halftone mask.

[0055] After the photoresist layer 230a is formed, the first conductive layer 231a and the second conductive layer 232a are patterned, that is the areas that are not covered by the photoresist layer 230a are removed by dry etching. The photoresist layer 230a on the second area A2 is also removed. In particular, in the dry etching process, the photoresist layer 230a on the first area A1, the photoresist layer 230a on the second area A2, and the photoresist layer 230a on the third area A3 are etched. Since the thickness t1 of the photoresist layer 230a on the first area A1 and the thickness t3 of the photoresist layer 230a on the third area A3 are greater than the thickness t2 of the photoresist layer 230a on the second area A2, the etching does not completely remove the photoresist layer 230a on the first area A1 or the photoresist layer 230a on the third area A3, although the photoresist layer 230a on the second area A2 is removed. The photoresist layer 230a on the first area A1 maintains a thickness t1' and the photoresist layer 230a on the second area A3 maintains a thickness t3', as illustrated in FIG. 3B.

[0056] When the first conductive layer 231a and the second conductive layer 232a are patterned, at area A1, a gate electrode 230 is formed of first conductive layer 231 and second conductive layer 232 (that is, of a remaining portion of the

first conductive layer 231a and second conductive layer 232a). At area A2, a pixel electrode 310 and a second conductive material layer 311 are formed of the same material as the first conductive layer 231 of the gate electrode 230 on a same layer as the first conductive layer 231 and the second conductive layer 232 of the gate electrode 230. At area A3, a wiring 410 is formed including a first conductive layer 411 and a second conductive layer 412 on the first conductive layer 411 (that is, of a remaining portion of the first conductive layer 231a and the second conductive layer 232a).

[0057] Then, by removing the second conductive material layer 311 on the second area A2, the photoresist layer 230a remaining on the first area A1, and the photoresist layer 230a remaining on the third area A3, a multilayer body may be obtained as illustrated in FIG. 3C, wherein in the multilayer body, the gate electrode 230 including the first conductive layer 231 and the second conductive layer 232 on the first conductive layer 231 is disposed on the first area A1, the pixel electrode 310 formed by using the same material as the first conductive layer 231 of the gate electrode 230 on the same layer as the first conductive layer 231 of the gate electrode 230 is disposed on the second area A2, and the wiring 410 including the first conductive layer 411 and the second conductive layer 412 on the first conductive layer 411 is formed on the third area A3. The second conductive material layer 311 on the second area A2, the photoresist layer 230a remaining on the first area A1, and the photoresist layer 230a remaining on the third area A3 may be removed by dry etching.

[0058] As can be seen from the above description, the gate electrode 230, the pixel electrode 310, and the wiring 410 may be formed after performing only two mask processes. By contrast, in the conventional method of manufacturing the organic light emitting display device described with reference to FIGS. 1A through 1L, only two mask processes are required so as to form the gate electrode 23 but separate mask processes are further required to form the pixel electrode 31. Thus, the conventional method requires more mask processes than are used in the method of manufacturing the organic light emitting display device according to the current embodiment of the present invention. Thus, according to the method of manufacturing the organic light emitting display device according to the current embodiment of the present invention, a manufacturing process may be simplified, manufacturing costs may be reduced, and yield may be increased.

[0059] Next, after the gate electrode 230, the pixel electrode 310, and the wiring 410 are formed as illustrated in FIG. 3C, a process similar to a process which has been described with reference to FIGS. 2D through 2J is performed, and then an AM organic light emitting display device having an OLED 300 as a pixel, whose emission is controlled by a TFT 200 is manufactured.

[0060] According to the conventional method of manufacturing the organic light emitting display device described with reference to FIGS. 1A through 1L, a total of eight mask processes are required. However, by using the method of manufacturing the organic light emitting display device according to the current embodiment of the present invention, are required to manufacture an AM organic light emitting display device can be manufactured using a total of six mask processes. Thus, according to the method of manufacturing the organic light emitting display device according to the

current embodiment of the present invention, a manufacturing process may be simplified, manufacturing costs may be reduced, and yield may be increased.

[0061] FIG. 3D illustrates an organic light emitting display device of FIG. 3D that is manufactured according to the method described above. The organic light emitting display device includes a TFT 200, a pixel electrode 310 electrically connected to one of source/drain electrodes 250 of the TFT 200, and a wiring 410. A gate electrode 230 includes a first conductive layer 231 and a second conductive layer 232 on the first conductive layer 231. The pixel electrode 310 is formed of the same material as the first conductive layer 231 of the gate electrode 230 on a same layer as the first conductive layer 231 of the gate electrode 230, and the wiring 410 has the same structure and is formed of the same layers as the gate electrode 230. Such a first conductive layer 231 may be formed of transparent conductive materials such as ITO, IZO and In_2O_3 . The organic light emitting display device according to the present embodiment has a simple structure and can be formed with fewer mask processes, thereby enabling an increase in production yield and a reduction in manufacturing costs, compared to the conventional organic light emitting display device as illustrated in FIG. 1L.

[0062] Furthermore, in the conventional organic light emitting display device of FIG. 1L, manufactured by using the conventional method, the pixel electrode 31 is disposed on a top surface of the TFT 20 such that the gate insulating layer 11, the intermediate insulating layer 13, and the planarization layer 15 are interposed between the substrate 10 and the pixel electrode 31. However, in the organic light emitting display device of FIG. 3D according to aspects of the present invention (manufactured by using the method of manufacturing the organic light emitting display device illustrated in FIGS. 3A through 3C), the pixel electrode 310 is disposed in a same layer as the first conductive layer 231 of the gate electrode 230 so that only the gate insulating layer 110 is interposed between the pixel electrode 310 and the substrate 100. Thus, in a bottom emission type organic light emitting display device, the number of layers through which a light emitted from the intermediate layer 320 in a rear emission organic light emitting display device passes before being emitted to the outside via the pixel electrode 310 and the substrate 100 is greatly reduced, compared to the number of layers through which a light in the conventional organic light emitting display device passes before being emitted to the outside. Therefore, optical efficiency may be greatly enhanced.

[0063] Also, the number of layers included in the organic light emitting display device of FIG. 3D according to aspects of the present invention is reduced, compared to the number of layers included in the conventional organic light emitting display device of FIG. 1L, thus, it may be possible to simplify a structure of the organic light emitting display device so as to increase yield and reduce manufacturing costs.

[0064] The organic light emitting display device and the method of manufacturing the same can embody an organic light emitting display device which reduces the number of times that masks are used, reduces manufacturing costs, and simplifies manufacture thereof.

[0065] Although a few embodiments of the present invention have been shown and described, it would be appreciated by those skilled in the art that changes may be made in this embodiment without departing from the principles and spirit of the invention, the scope of which is defined in the claims and their equivalents.

What is claimed is:

1. An organic light emitting display device comprising:
a thin film transistor (TFT) having a gate electrode, a source electrode and a drain electrode which are insulated from the gate electrode, and a semiconductor layer which is insulated from the gate electrode and which contacts each of the source electrode and the drain electrode; and

a pixel electrode electrically connected to one of the source electrode and the drain electrode,

wherein the gate electrode comprises a first conductive layer and a second conductive layer on the first conductive layer, and the pixel electrode is formed of a same material as the first conductive layer of the gate electrode on a same layer as the first conductive layer of the gate electrode.

2. The organic light emitting display device of claim 1, wherein the first conductive layer is formed of a transparent conductive material.

3. The organic light emitting display device of claim 1, wherein the first conductive layer is formed of a material that is more difficult to etch than a material that forms the second conductive layer.

4. The organic light emitting display device of claim 1, wherein the first conductive layer is formed of indium tin oxide, indium zinc oxide or In_2O_3 and the second conductive layer is formed of Mo, W, Al, Cu, Ag, or an alloy thereof.

5. The organic light emitting display device of claim 1, further comprising a wiring electrically connected to the gate electrode,

wherein the wiring comprises a first layer of conductive material on the same layer as the first conductive layer of the gate electrode and a second layer of conductive material on a same layer as the second conductive layer of the gate electrode.

6. The organic light emitting display device of claim 5, wherein the first layer of conductive material of the wiring comprises the same material as the first conductive layer of the gate electrode and the second layer of conductive material of the wiring comprises a same material as the second conductive layer of the gate electrode.

7. A bottom emission type organic light emitting display device comprising a gate electrode and a pixel electrode formed directly on a gate insulating layer that is formed on a substrate through which light is emitted, wherein the pixel electrode and a first layer of the gate electrode are formed from a same layer of conductive material.

8. The bottom emission type organic light emitting display device of claim 7, further including wiring that is formed directly on the gate insulating layer, wherein a first layer of the wiring is also formed from the same layer of conductive material.

9. A method of manufacturing an organic light emitting display device, the method comprising:

forming a first conductive layer and a second conductive layer on the first conductive layer, the first conductive layer being formed on a substrate;

forming a patterned photoresist layer on a first area of the second conductive layer corresponding to where a gate electrode is to be formed and on a second area of the second conductive layer corresponding to where a pixel electrode is to be formed, wherein the patterned photo-

- resist layer has a greater thickness at the first area than at the second area;
- patterning the first conductive layer and the second conductive layer by removing portions of the first conductive layer and the second conductive layer not covered by the patterned photoresist layer, and removing the patterned photoresist layer on the second area; and
- removing the second conductive layer of the second area to form the pixel electrode and removing the patterned photoresist layer remaining on the first area to form the gate electrode.
- 10.** The method of claim **9**, wherein the first conductive layer is formed of a transparent conductive material.
- 11.** The method of claim **9**, wherein the first conductive layer is formed of a material that is more difficult to etch than a material that forms the second conductive layer.
- 12.** The method of claim **9**, wherein the first conductive layer is formed of indium tin oxide, indium zinc oxide or In_2O_3 and the second conductive layer is formed of Mo, W, Al, Cu, Ag, or an alloy thereof.
- 13.** The method of claim **9**, wherein the first conductive layer and the second conductive layer are formed sequentially.
- 14.** The method of claim **9**, wherein the first conductive layer and the second conductive layer are formed concurrently.

15. The method of claim **9**, wherein the patterned resist layer on the first area is partially removed in a thickness direction concurrent with the removing of the patterned resist layer on the second area.

16. The method of claim **9**, wherein the forming of the patterned photoresist layer on the first area and the second area is carried out using a halftone mask.

17. The method of claim **9**, further including forming the patterned photoresist layer on a third area of the second conductive layer corresponding to where a wiring electrically connected to the gate electrode is to be formed, concurrently with the forming of the patterned photoresist layer on the first area and the second area, and wherein the thickness of the patterned photoresist layer on the third area is greater than the thickness of the patterned photoresist layer on the second area and further including removing the patterned photoresist layer from the third area concurrently with the removing of the patterned photoresist layer from the first area and the removing of the second conductive layer from the second area.

18. The method of claim **17**, wherein the thickness of the patterned photoresist layer on the third area is equal to the thickness of the patterned photoresist layer on the first area.

19. The method of claim **17**, wherein the forming of the patterned photoresist layer on the first area, the second area and the third area is carried out using a halftone mask.

* * * * *

专利名称(译)	有机发光显示装置及其制造方法		
公开(公告)号	US20090267074A1	公开(公告)日	2009-10-29
申请号	US12/342170	申请日	2008-12-23
[标]申请(专利权)人(译)	三星显示有限公司		
申请(专利权)人(译)	三星移动显示器有限公司		
当前申请(专利权)人(译)	三星DISPLAY CO. , LTD.		
[标]发明人	KWON DO HYUN LEE IL JEONG IM CHOONG YOUL NO DAE HYUN YEO JONG MO YU CHEOL HO		
发明人	KWON, DO-HYUN LEE, IL-JEONG IM, CHOONG-YOUL NO, DAE-HYUN YEO, JONG-MO YU, CHEOL-HO		
IPC分类号	H01L51/50 H01L21/56		
CPC分类号	H01L27/3248 H01L29/4908 H01L27/124 H01L27/1288 H01L2227/323		
优先权	1020080038255 2008-04-24 KR		
其他公开文献	US9171892		
外部链接	Espacenet USPTO		

摘要(译)

一种有机发光显示装置，包括薄膜晶体管（TFT），该薄膜晶体管具有与栅电极绝缘的栅电极，源电极和漏电极，以及与栅电极绝缘并且与栅电极接触的半导体层。源电极和漏电极；像素电极与源电极和漏电极之一电连接。栅电极由第一导电层和第一导电层上的第二导电层构成，像素电极由与第一导电层位于同一层的栅电极的第一导电层相同的材料形成栅电极。

